

S216D/C216D Flanged ball valve PN16-PN40 - DN 15 up to DN 100

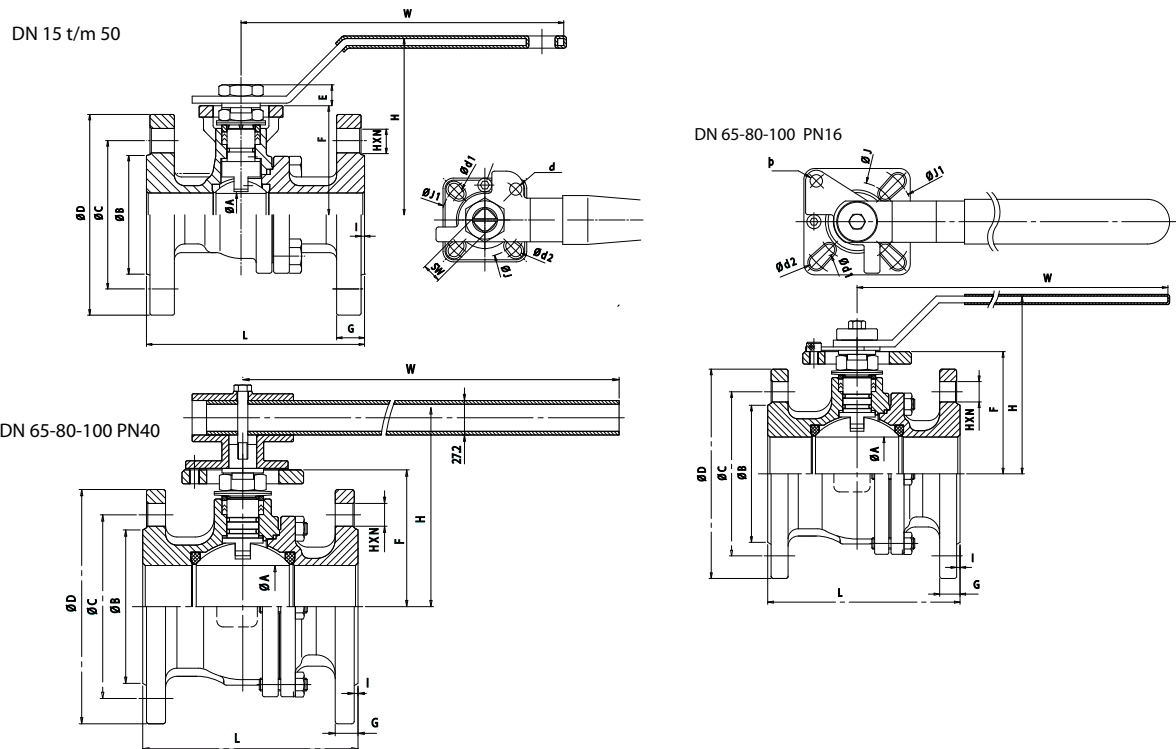

Dimensions DN 15 up to DN 50 PN16/40 [mm]							DN 65 up to DN 100 PN16 [mm]			DN 65 up to DN 100 PN40 [mm]		
DN	15	20	25	32	40	50	65	80	100	65	80	100
A	16	20	25	32	38	50	65	80	96	65	80	96
C	65	75	85	100	110	125	145	160	180	145	160	190
D	95	105	115	140	150	165	185	200	220	185	200	235
H	89	89	101	112	116	125	154	165	180	150	160	175
W	114	114	187	187	222	222	350	350	350	265	365	365
G	16	18	18	18	18	20	18	20	20	22	24	24
J	36	36	42	42	50	50	70	70	70	70	70	102
J1	42	42	50	50	70	70	102	102	102	102	102	125
d	6	6	6	6	7	7	9	9	9	9	9	11
d1	6	6	7	7	9	9	11	11	11	11	11	13
SW	9	9	11	11	14	14	17	17	17	17	17	22
H x NM	14x4	14x4	14x4	18x4	18x4	18x4	18x4	18x8	18x8	18x8	18x8	22x8
L	115	120	125	130	140	150	170	180	190	170	180	190
I	2	2	2	2	3	3	3	3	3	3	3	3
F	54	56	62.5	72	78	87.2	107	117.3	132.3	107	117.3	132.3
E	8	8	12	12	14.8	14.8	17.1	17.1	17.1	17.1	17.1	22
Weight [kg]	2.28	2.86	3.84	5.32	6.56	9.04	13.94	17.58	24	15.8	20.5	32.0

S216D/C216D Flanged ball valve PN16-PN40 - DN 15 up to DN 100

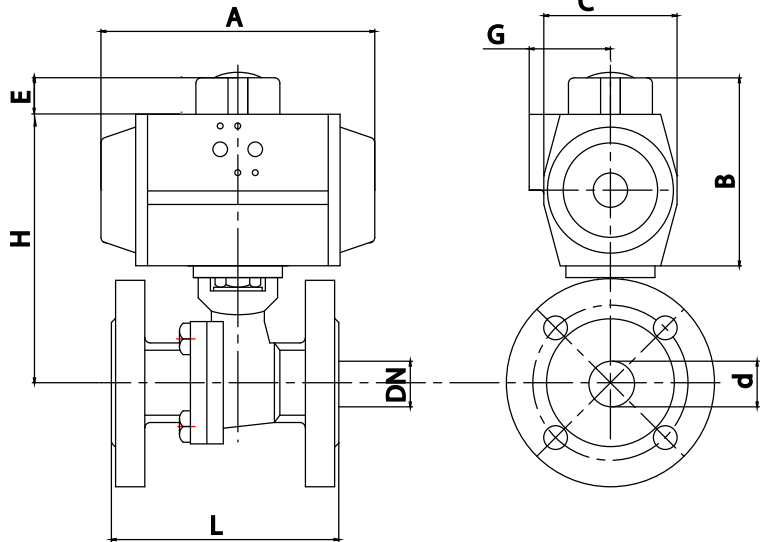

With double acting pneumatic actuator [mm]										PN16-40	PN16	PN40
DN	DW	A	B	C	d	E	G	H	L	Weight [kg]	Weight [kg]	Weight [kg]
DN15 (1/2")	AP1D	137	87	60	16	20	41	121	115	3.3		
DN20 (3/4")	AP1D	137	87	60	20	20	41	123	120	3.8		
DN25 (1")	AP2D	150	103	73	25	20	44.5	145.5	125	5.2		
DN32 (1 1/4")	AP2D	150	103	73	32	20	44.5	155	130	6.6		
DN40 (1 1/2")	AP3D	204	120	85	38	20	49.5	178	140	9.0		
DN50 (2")	AP3D	204	120	85	50	20	49.5	187.2	150	11.5		
DN65 (2 1/2")	AP3.5D	230	130	98	65	20	53	217	170		17.7	19.4
DN80 (3")	AP3.5D	230	130	98	80	20	53	227.3	180		21.1	24.2
DN100 (4")	AP4.5D	305	172	128	96	30	69	272.3	190		33.0	41.0

With single acting pneumatic actuator [mm]										PN16-40	PN16	PN40
DN	EW	A	B	C	d	E	G	H	L	Weight [kg]	Weight [kg]	Weight [kg]
DN15 (1/2")	AP2S	150	103	73	16	20	44.5	137	115	4.0		
DN20 (3/4")	AP2S	150	103	73	20	20	44.5	139	120	4.4		
DN25 (1")	AP3S	204	120	85	25	20	49.5	162.5	125	6.7		
DN32 (1 1/4")	AP3S	204	120	85	32	20	49.5	172	130	8.2		
DN40 (1 1/2")	AP3.5S	230	130	98	38	20	53	188	140	11.0		
DN50 (2")	AP3.5S	230	130	98	50	20	53	197.2	150	13.4		
DN65 (2 1/2")	AP4S	271	145	110	65	30	58	222	170		19.6	21.3
DN80 (3")	AP4.5S	305	172	128	80	30	69	259.3	180		26.7	29.8
DN100 (4")	AP5S	360	185	140	96	30	-	287.3	190		37.02	45.0

Pneumatic actuators are based on PTFE seat rings, minimum air pressure of 6 bar(g) and medium of clean water 20°C with at 6 bar pressure